



Item: RF Controller.

Model No: VT-2404

SKU: 3303

Product Description:

RF controller adopts the advanced micro control unit. It is used for controlling a variety of constant voltage LED lights. For instance, led source, flexible led strip, wall washer and so on. You could adjust brightness, static color choices and various dynamic changes in lighting effects through wireless remote control. According to the actual need of customers, it can carry out jumpy changing, gradual changing, strobe flash and other effects of change.

Technical Parameters:

- Working temperature: -20-60°C
- Input voltage: DC12~24V
- Output: 3 Circuit
- Connection mode: Common anode
- Static power consumption: <1W
- Output current: <4A/channel
- Output power: 12V/4A < 144W; 24V< 288W

Connection description:

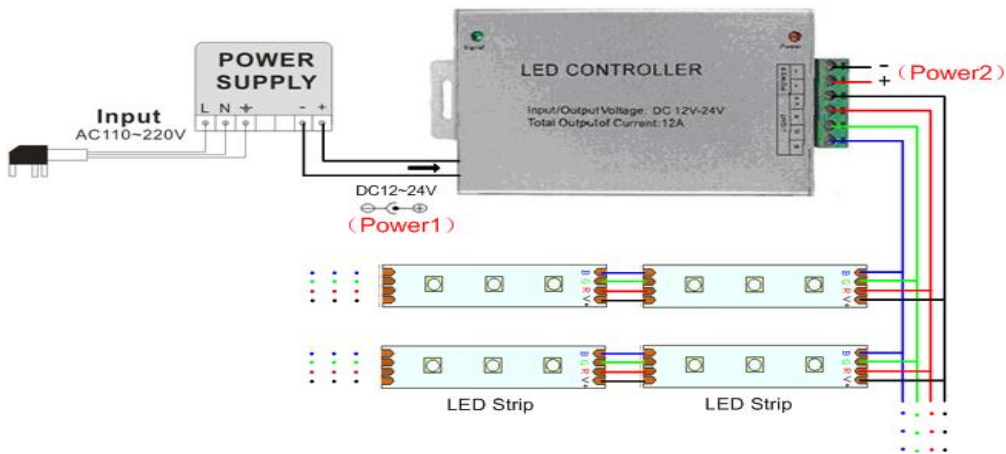

Remote Controller Functions

Symbol	Button Name	Instruction
	Program	The style/color function key. You can choose different color changes, each press one time, change a light style.
	Speed up	To speed up lighting color changing, with continuous reception.
	Speed down	To speed down lighting color changing, with continuous reception.
	On/off	The output switch, turn on or off the controller output at any state.

- Press each time, the green light flash one time, indicating that has entered the next state.
- Standard color changes as follows:

Items	Patterns	Remarks
1	Static red	2(B) and 3(C) keys are used to adjust brightness
2	Static green	
3	Static yellow	

Items	Patterns	Remarks
4	Static blue	
5	Static purple	
6	Static cyan	
7	Static white	
8	Three-color jumpy changing	<i>2(B) and 3(C) keys are used to adjust changing speed</i>
9	Seven-color jumpy changing	
10	Three-color gradual changing	
11	Seven-color gradual changing	



CAUTION

- This product's Input voltage is DC12V~24V. Other input voltages are not allowed.
- Ensure that the lead wires are connected correctly, according to the wire color and as per the above diagram.
- Overloads are prohibited.